

ARRANGEMENT OF TRAINLOAD TROLLEY & TRAINLOAD ACTUATORS

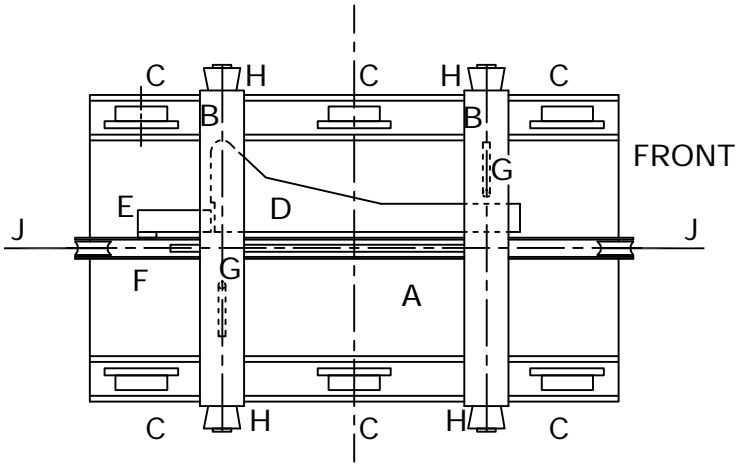

- A = Bedframe
- B = Cross tube
- C = Running wheels
- D = Radial arm
- E = Balance arm
- F = Sliding bars
- G = Actuating spindle
- H = Contactor wheel
- J = Wire rope

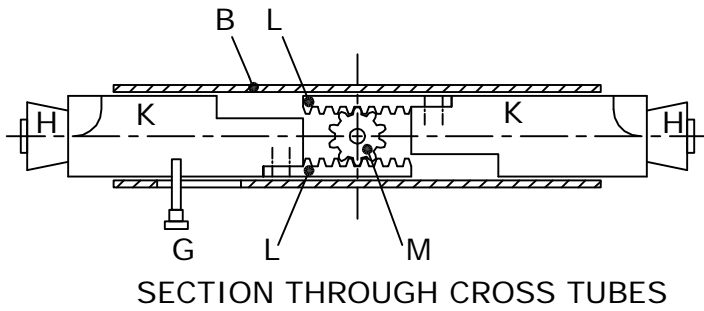

- B = Piston tube
- G = Actuating spindle
- K = Piston arm
- L = Racks
- M = Pinion
- H = Contactor wheel

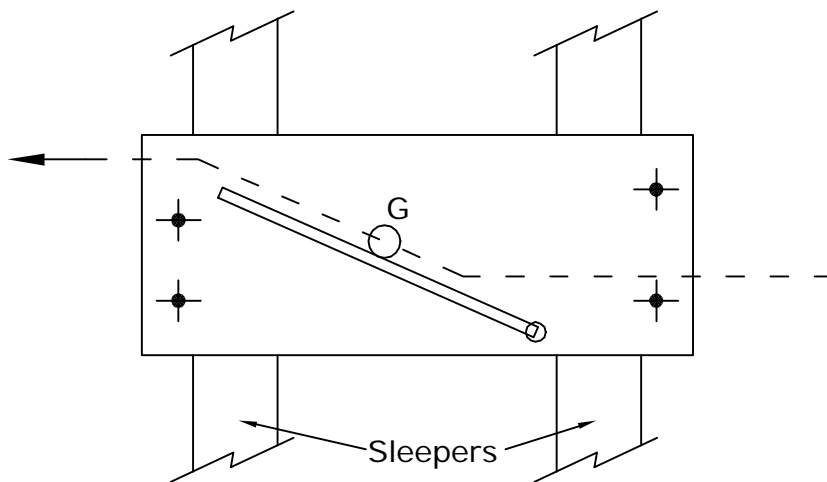

OPERATION OF TRAINLOAD TROLLEY (1 of 5)

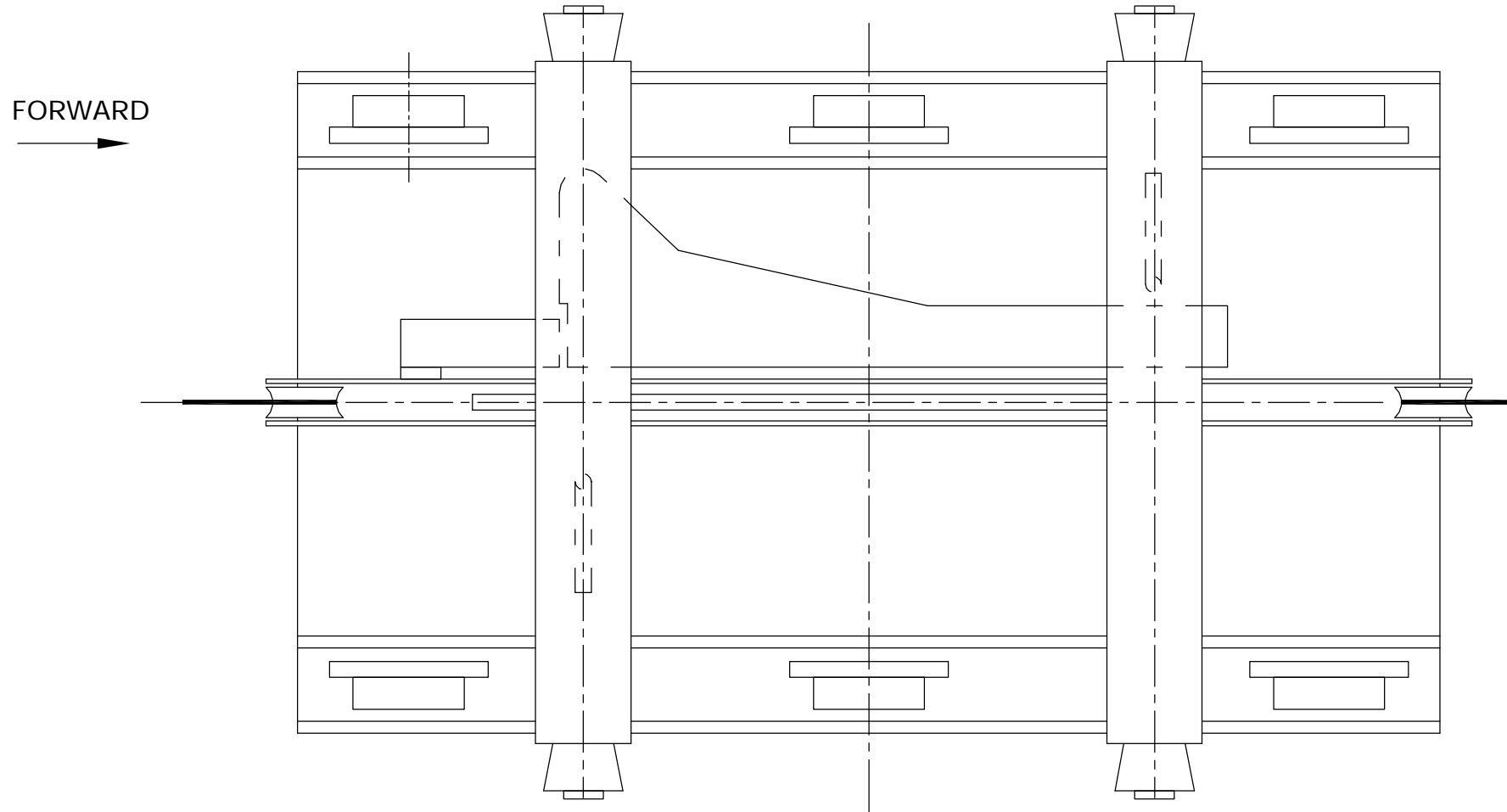

1 -Trolley is at rest in the start position with both cross tubes retracted and the radial arm in the 'closed' position.

OPERATION OF TRAINLOAD TROLLEY (2 of 5)

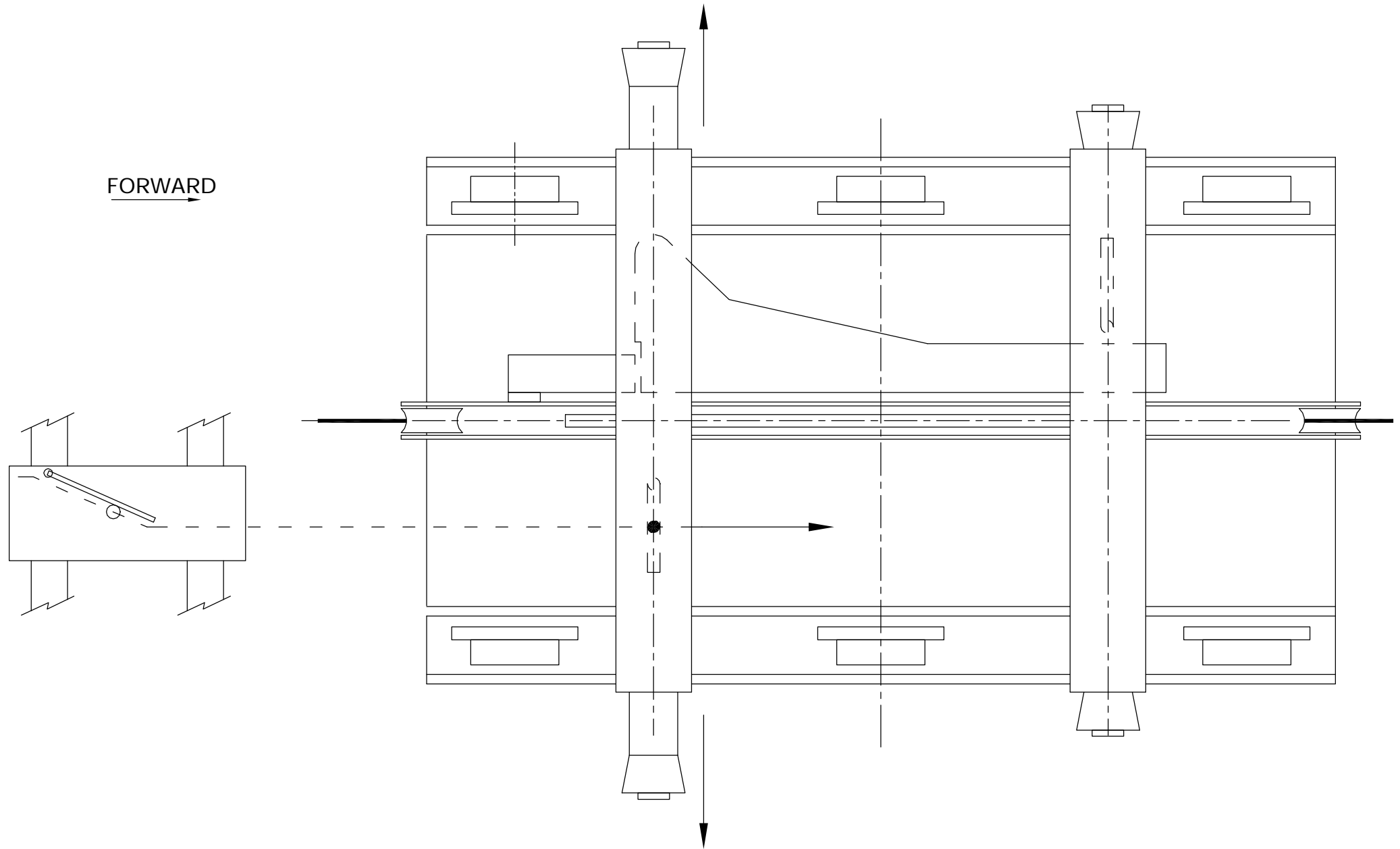

2 -Operator presses 'forward' button and the trolley moves off and over the first track actuator which extends the rear pistons.

OPERATION OF TRAINLOAD TROLLEY (3 of 5)

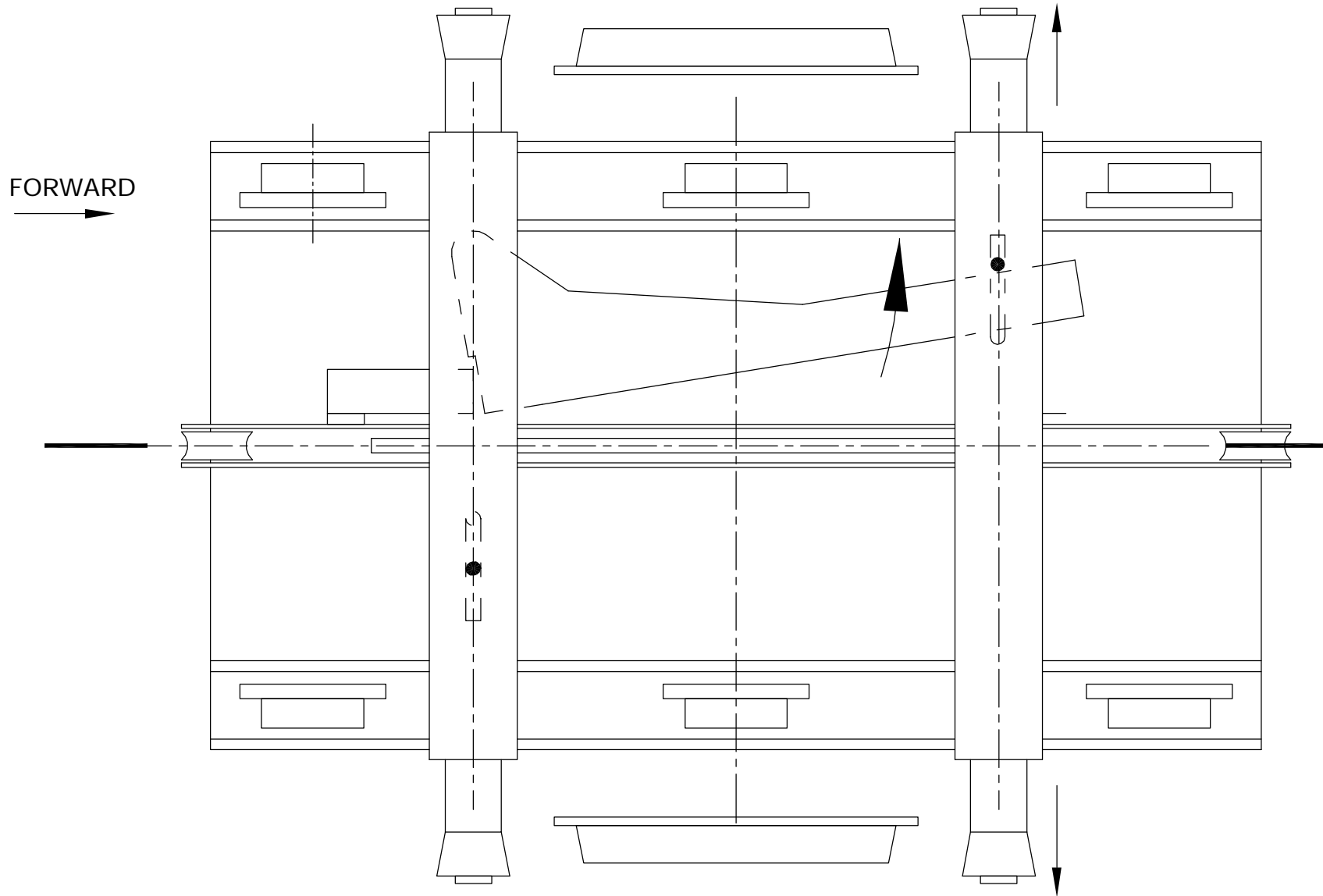

- 3 -Trolley continues to travel until extended rear arms contact the first pair of train wheels. This contact brings the trolley momentarily to a halt but the wire & sliding bars continue to move ahead with the attached balance arm causing the radial arm to partially rotate and bring out the front pistons. The train then starts to move, fully restrained in either direction, under the complete control of the operator. It can now be stopped and moved in either direction by the remote controls.
- 4 Loading/Unloading now takes place under the control of the operator. On completion of the Loading/Unloading, the operator has only to once more press the 'forward' button and the following sequence automatically takes place:

OPERATION OF TRAINLOAD TROLLEY (4 of 5)

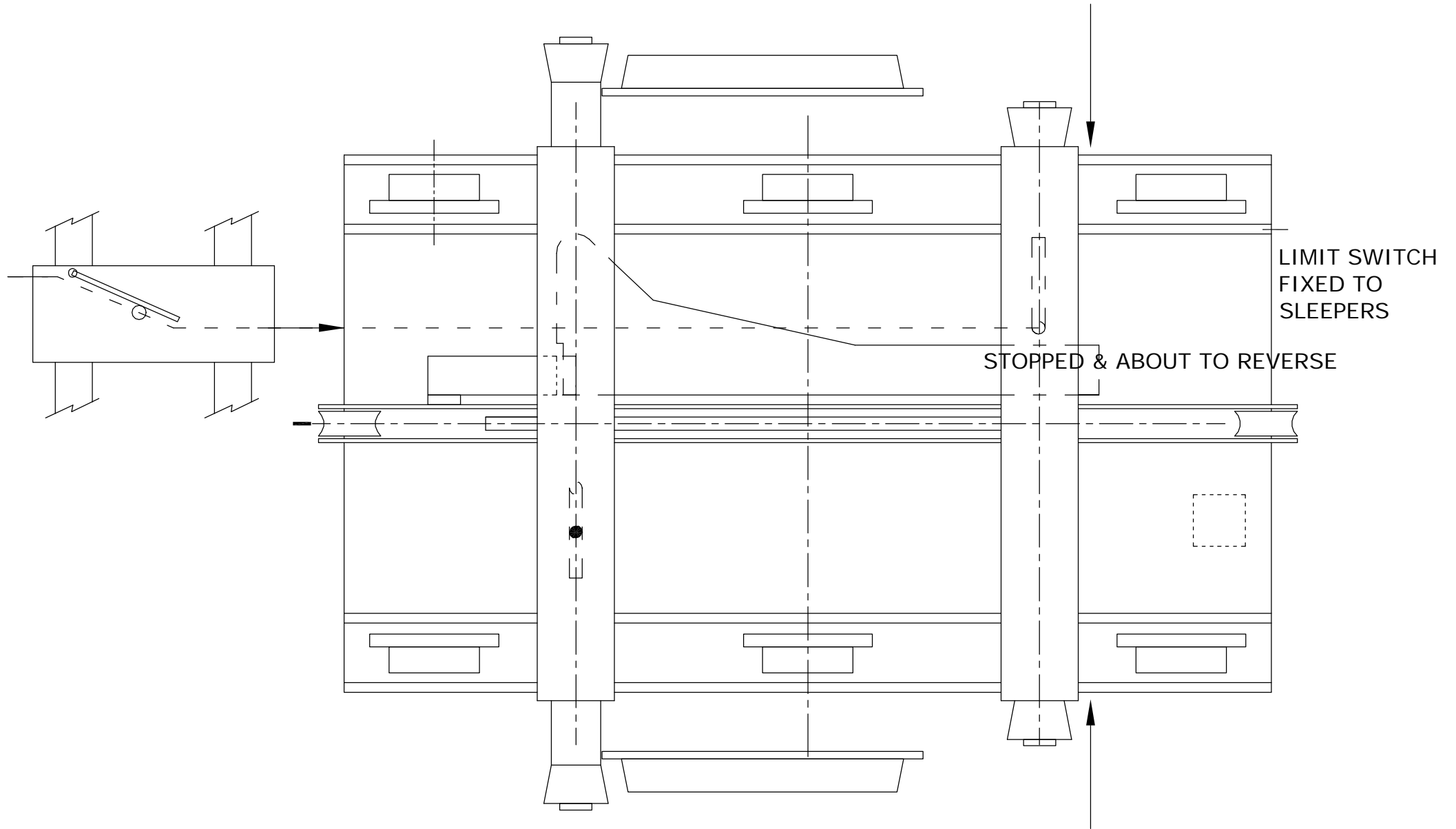

5 -The trolley passes over a track actuator which retracts the front arms. At the same time, a track limit switch stops the trolley and immediately reverses it.

OPERATION OF TRAINLOAD TROLLEY (5 of 5)

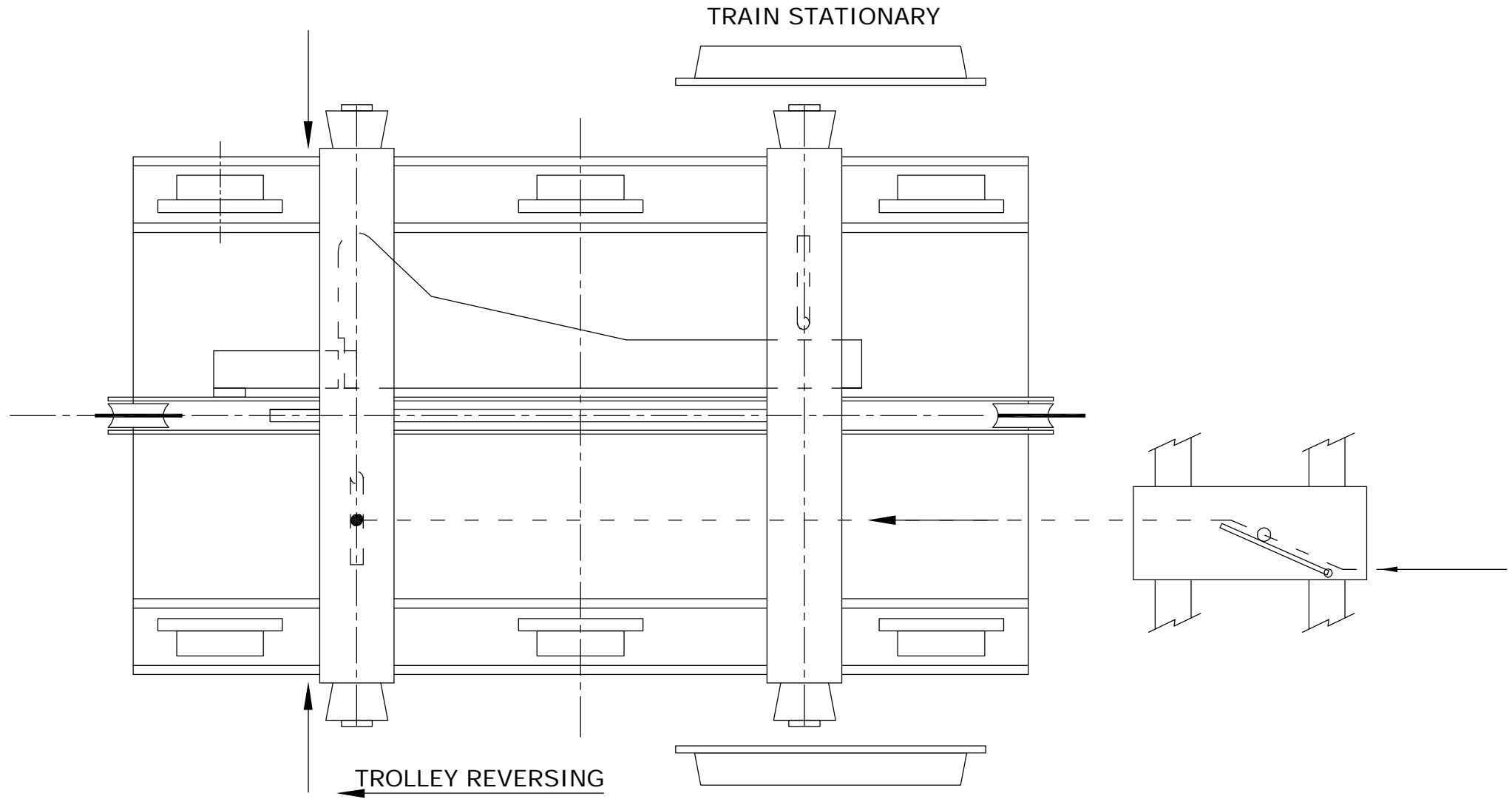

6 -Immediately on reversing, the trolley passes over another track actuator which retracts the rear arms. The trolley is now completely detached. In practice, the track actuators and limit switch mentioned in paras. 5 and 6 are set very closely together so that the train detachment takes place in a matter of seconds.

The trolley continues in the reverse direction until it stops in the original 'start' position, and is now ready for the next cycle.